

CURVE DI CARICO - DIAGRAMME DE CHARGE  
CAPACITY CHART - SKIZZE DER HEBEKAPAZITÄT

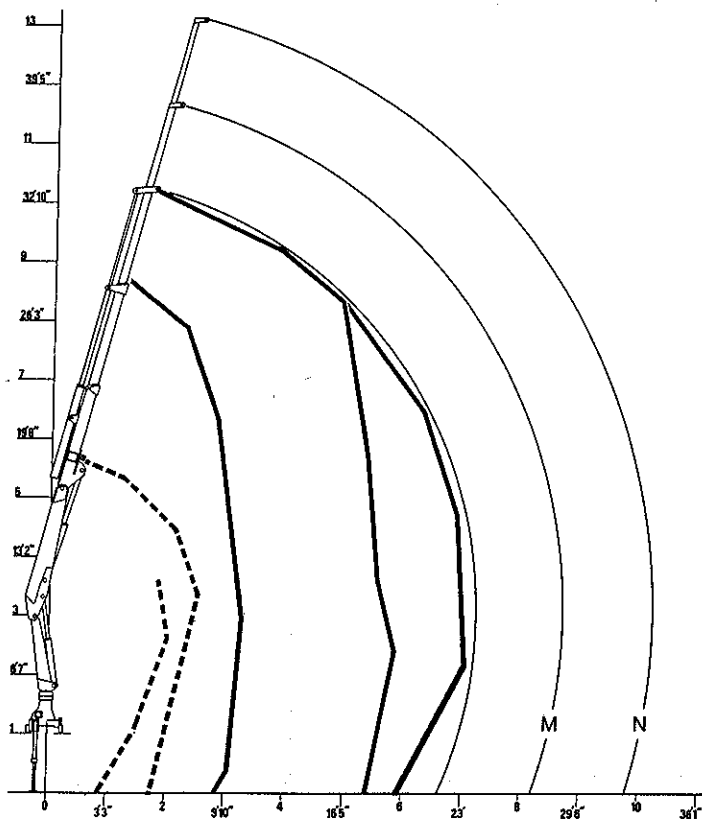

CURVE DI CARICO - DIAGRAMME DE CHARGE CAPACITY CHART - SKIZZE DER HEBEKAPAZITÄT		PORTATE - CAPACITIES CAPACITIES - HEBELEISTUNG
PRIMO GANCIO HEAVY LIFT HOOK CROCHET CENTRAL ENTSCWERLASTHAKEN	GANCIO MOBILE SWIVELING HOOK CROCHET D'EXTREMITÉ HAKEN FÜR AUSLEGER	PROLUNGHE MECCANICHE MANUAL EXTENSIONS RALLONGES MANUELLES MANUELLE VERLÄNGERUNGEN
Kg 4100 lbs 9041	Kg 2700 lbs 5954	
Kg 3400 lbs 7497	Kg 2110 lbs 4653	<b>M</b> Kg 720 lbs 1588
	Kg 1470 lbs 3241	<b>N</b> Kg 430 lbs 948
	Kg 1100 lbs 2426	
PORTATE PER UTILIZZO GANCIO CAPACITIES WHEN OPERATING WITH HOOK PUISSANCES POUR UTILISATION AU CROCHET HEBELEISTUNG FÜR HAKENBETRIEB		

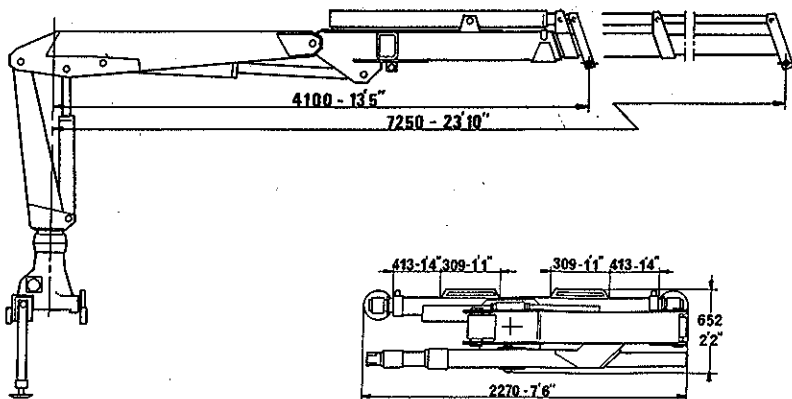

# F90.22

DATI TECNICI TECHNICAL DATA DONNÉES TECHNIQUES TECHNISCHE DATEN	METRIC SYSTEM	AMERICAN MEAS
Capacità di sollevamento Lifting capacity Abaque de levage Hubvermögen	kNm 85,3 (8,7 tm)	lbs.ft 63306
Sbraccio standard Standard reach Bras standard Standardarm	m 7,25	ft 23'10"
Estensione idraulica Hydraulic extension Extension hydraulique Hydraulischen Ausschub	m 3,15	ft 10'4"
Tempo uscita/entrata Extension/retraction time Temps sortie/rentrée Aus- und Einfahrzeit der Ausschube	sec 31/16	sc 31/16
Sbraccio/portate Reach/capacity Bras/capacité Reichweite/Hebeleistung	m Kg	ft lbs
	2,10 - 4100	6'11" - 9041
	2,55 - 3400	8'4" - 7497
	4,10 - 2110	13'5" - 4653
	5,65 - 1470	18'7" - 3241
	7,25 - 1100	23'10" - 2426
8,75 - 720	28'9" - 1588	
10,25 - 430	33'8" - 948	
Angolo di rotazione Rotation Rotation Schwenkbereich	400°	400°
Coppia di rotazione Rotation torque Couple de rotation Drehmoment	kNm 13,7 (1400 Kpm)	lbs.ft 10187
Tempo per 360° Time for 360° Temps pour 360° Zeit für 360°	sec 25	sc 25
Pressione d'esercizio Working pressure Pression d'utilisation Betriebsdruck	MPa 24,5 (250 bar)	psi 3555
Portata della pompa Pump capacity Débit de la pompe Erforderliche Pumpenleistung	l/min 25	gal/min 7
Capacità serbatoio olio Oil tank capacity Capacité du réservoir d'huile Fassungsvermögen des Öltanks	l 50	gals 13
Peso della gru Crane weight Poids de la grue Kranngewicht	Kg 1341	lbs 2957

DIMENSIONI - DIMENSIONS - MASSE

